

RSP Packaging line in heavy execution



RSP Packaging line in heavy execution with infeed conveyor, transfer unit and pallet magazine



RSP packaging line in heavy execution with infeed conveyor, hydraulic grab, transfer station with compactor, mechanic grab and slab conveyor

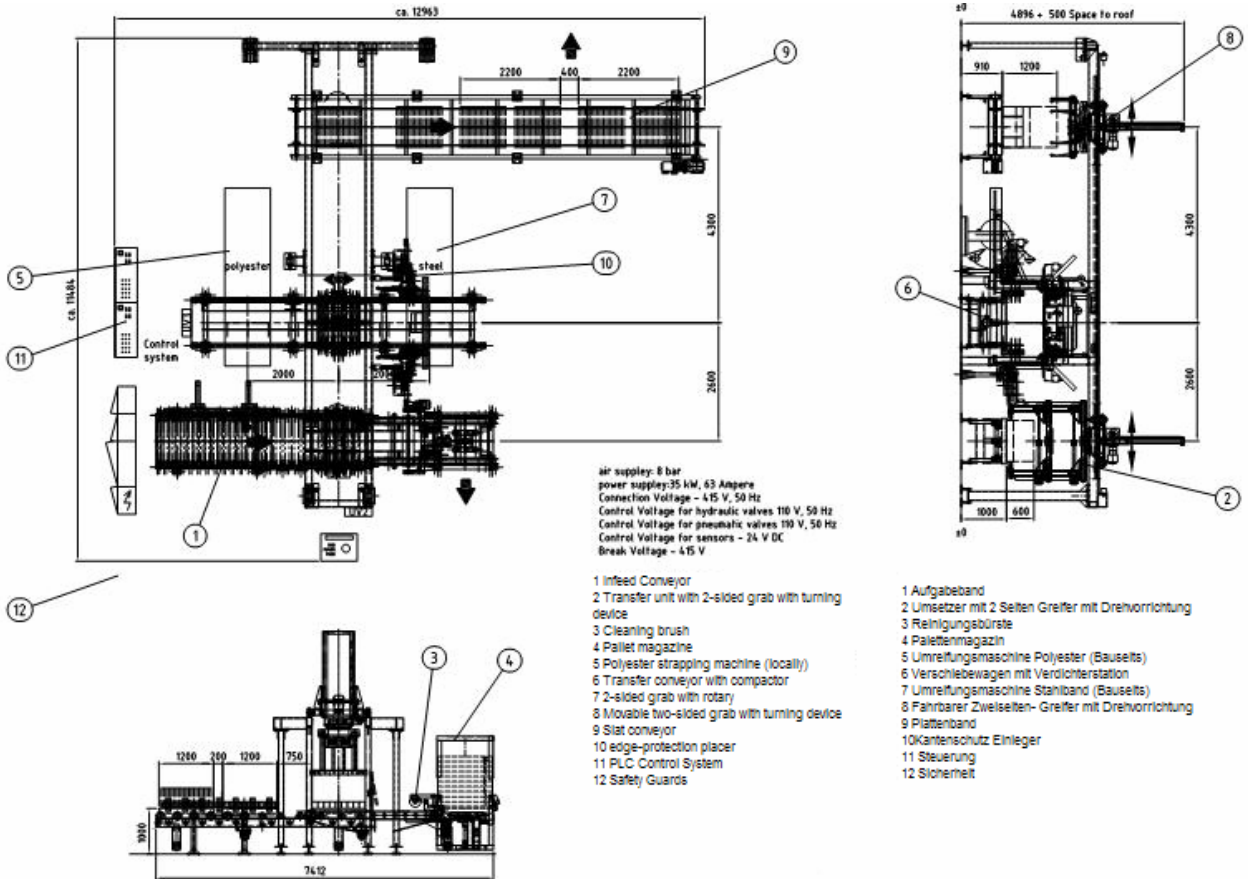

Typical layout for RSP packaging line in heavy execution



RSP Modul compactor and transfer station



RSP Module slab conveyor and mechanic grab

Advantages:

- individual packaging lines
- for all concrete products: slabs, kerbstones, pavers, special blocks

Description of the machine:

The packaging line in heavy execution consists of an infeed conveyor, hydraulic grab 1, compactor, can be mounted on the 2 strapping machines, mechanic grab 2 and a collection conveyor.

Grab 1 takes packs fed in, turns them by 90° and places them on compactor station. Gaps between products are closed there and products are transported on to vertical strapping machine. Strapping finished packs are placed on collection conveyor by means of grab 2. Ready-made packs may be collected by fork-lift there.

Zentrale
RIMAC Maschinen & Anlagen GmbH
Im Bruch 4-10
69256 Mauer
Tel: +49 (0) 6226 / 4291-0
Fax: +49 (0) 6226 / 4291-10

Niederlassung
RIMAC Maschinen & Anlagen GmbH
Paradeisstrasse 56
82362 Weilheim
Tel: +49 (0) 881 / 627-215
Fax: +49 (0) 881 / 627-278